

Description

An in-motion trolley scale allows trolleys to be weighed automatically, without intervention from an operator. This significantly enhances the efficiency of trolley checkweighing. Trolleys that are out of tolerance will be flagged for removal according to your preference.

Applications

- Pork Monorail Check Scale
- Beef Monorail Check Scale
- Lamb Monorail Check Scale
- Smokehouse Check Scale

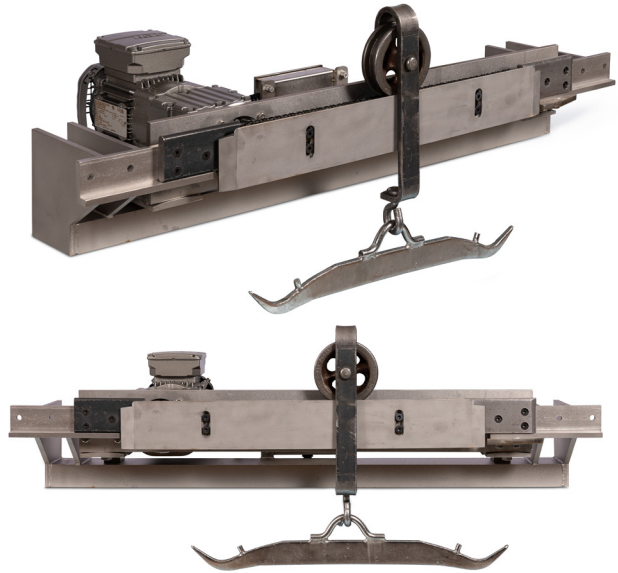

Features

- Elegant simplified design eliminates unnecessary moving parts, decreasing required maintenance
- Interfaces with any company's scale indicators
- Ruggedly constructed out of hardened steel for multiple decades of use
- Washdown safe, available in tool steel or full stainless steel
- Standardised chain significantly reduces maintenance cost

Physical Specification

Footprint (WxHxD)	37" x 6.5" x 11"
Weight	75lbs
Material	Full 17-4 Stainless or Full A2 Tool Steel

Motor Specification

RPM	30-71
Voltage	220 VAC or 440 VAC

Weighing Specification

Load Cell Type	2 x 150kg
Capacity	50lbs
Resolution	.02lbs
Rate	1200 Trolleys/Hour

Operating Conditions

Ideal Operating Temperature	14°F to 104°F (-10°C to 40°C)
------------------------------------	----------------------------------